

Functional elements:

- | | |
|-------|---|
| 1-15 | drive assembly |
| | hand feed with lever, flange SAE 3 |
| | gear: 12 teeth, 6/8 pitch, disengaging 28mm |
| 23 | air motor assembly |
| | operating pressure 8,2 bar (120psi), air consumption 59l/s (125 SCFM) |
| 25-32 | gear assembly |
| | gear ratio 1:100, output power 3.3KW, speed at max. power 33RPM |
| | breakaway-torque 1097Nm (811ft-lb), stall-torque 1396NM (1032ft-lb) |

Dimensions :

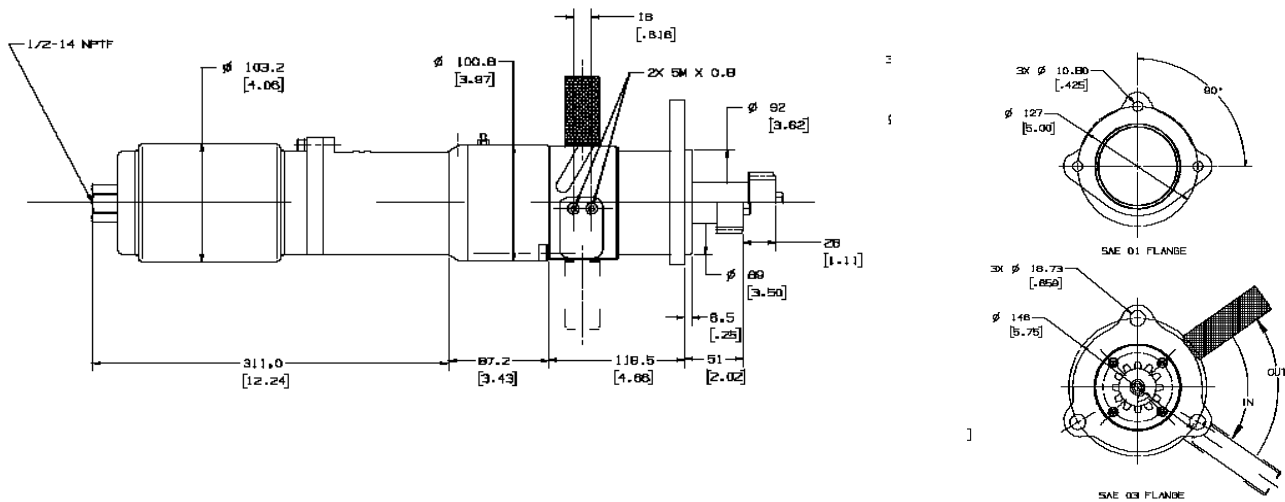

barring motor accessories:

hand control PT-15K



hand control with 3 hoses (15 ft.each)

reversible for both direction of rotation

article number:

BM1-SAE3-12.6.8-PT15K

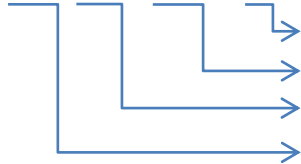

hand control
gear
flange type
turning motor



BM1 with hand control PT-15K